



FAYMONVILLE

TRAILERS TO THE **MAX**



DUALMAX



**Widening under load
- fast, safe and easy**



BÜLLINGEN (BE)

since 1988 - 30.000 m²



With an experience of **over 50 years**, Faymonville is one of the biggest manufacturers of semi-trailers for special and heavy haulage.

Faymonville provides their customers with optimal solutions and systems for any transport need outside the usual norms.

Quality, flexibility, productivity, creativity and service are the company's keywords. The range of products and services is constantly enlarged in tight collaboration with our customers.

GOLENIOW (PL)

since 2006 - 21.000 m²



The high level of **innovation** and the **excellent manufacturing quality** of the products are secured by optimized production processes and own modern production plants in Büllingen (Belgium), Lentzweiler (Luxembourg) and Goleniow (Poland). A service station has been opened in Noginsk (near Moscow, Russia).

NOGINSK (RU)

since 2014 - 3.120 m²



LENTZWEILER II (LU)

since 2015 - 16.000 m²



LENTZWEILER I (LU)

since 2003 - 20.250 m²

Widening under load fast, safe and easy

The DUALMAX is a modular platform trailer system, optimized for highest axle loads in the US. Its userfriendly operation allows safe, fast and flexible handling.

Main concept

- ✓ Hydraulic suspension with pendular axles
- ✓ Load per axle line 52 900 lbs
- ✓ Average tare weight of ± 13 200 lbs/axle line
- ✓ Can be operated with draw bar and/or gooseneck
- ✓ Use of loading decks or suspension beams from other brands
- ✓ Different widths 14' - 16' - 18' - 20'
- ✓ 4' track widening without changing or disassembling of steering rods
- ✓ Torsion resistant frame with high point load capacities on central beam and outer frames
- ✓ Quick and safe hydraulic widening under load without disconnecting any steering rods
- ✓ Foldable frame
- ✓ Total suspension stroke : 29 ½"



Technological aspects of the DualMAX

- EASE FOR USE gooseneck

Modern hydraulic and pneumatic technology in combination with state of the art neck design ensure a reliable operation and outstanding vehicle handling.

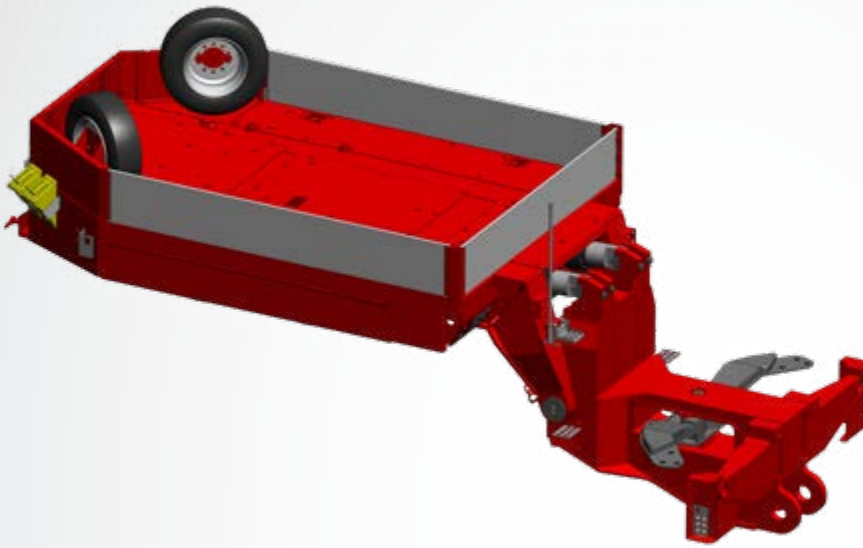

- Draw bar system

As an alternative to the gooseneck, drawbar systems are available in different lengths.

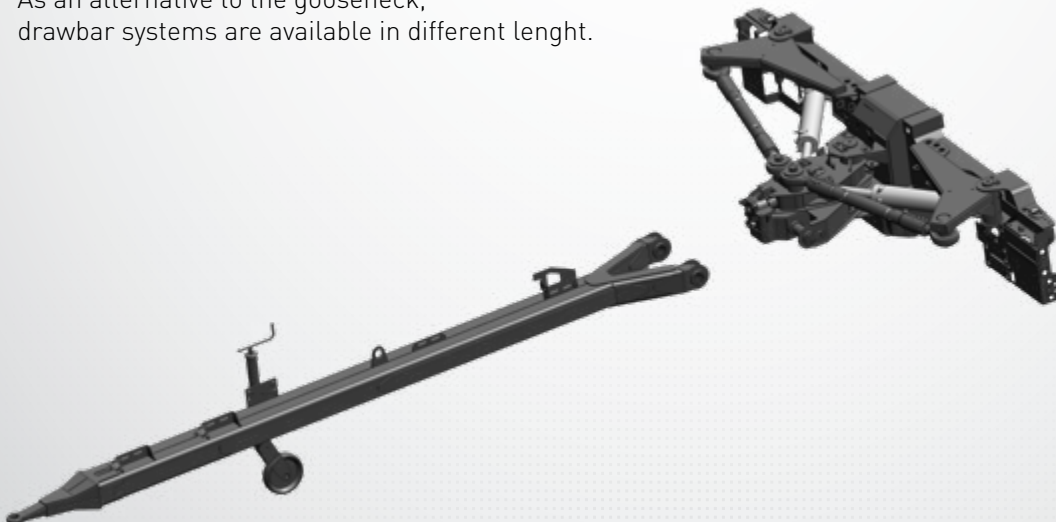

Lift and shift

Patented track widening system

- UNDER LOAD -

without touching/adapting any part of the steering unit.



13 ft 11 inch

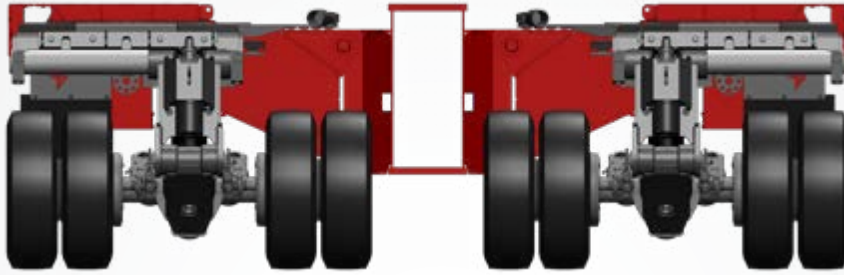

16 ft

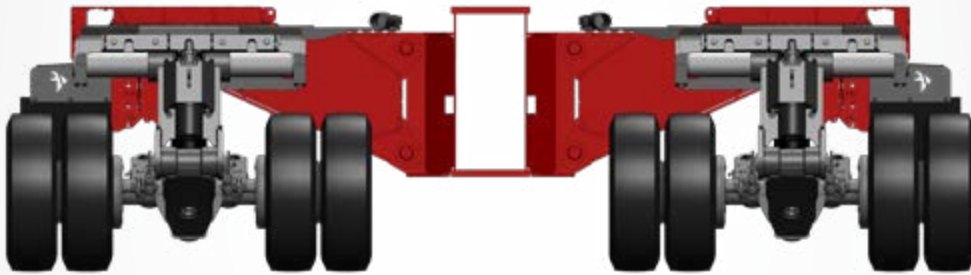

18 ft

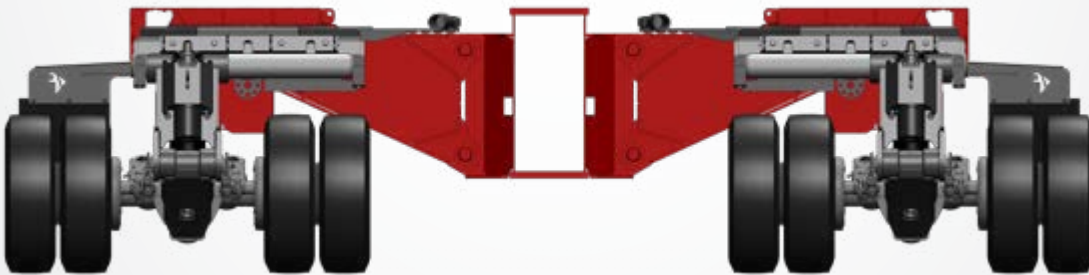

20 ft

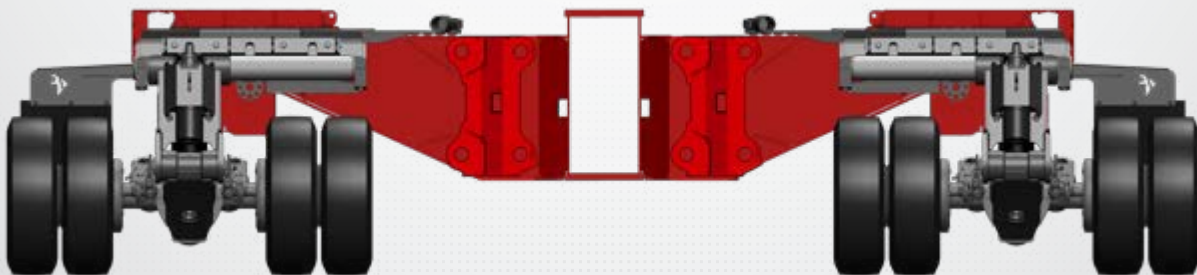

Foldable frame

< 10' width, for return transport

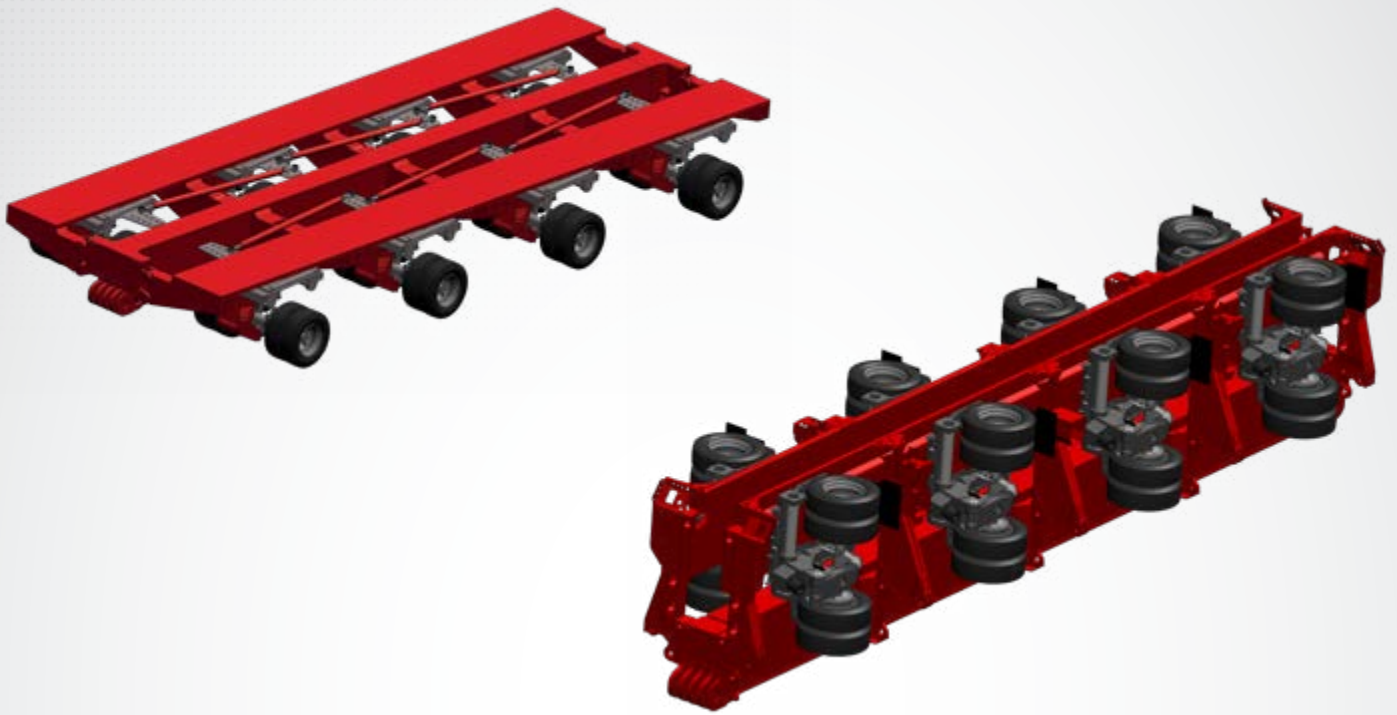

Dimensions

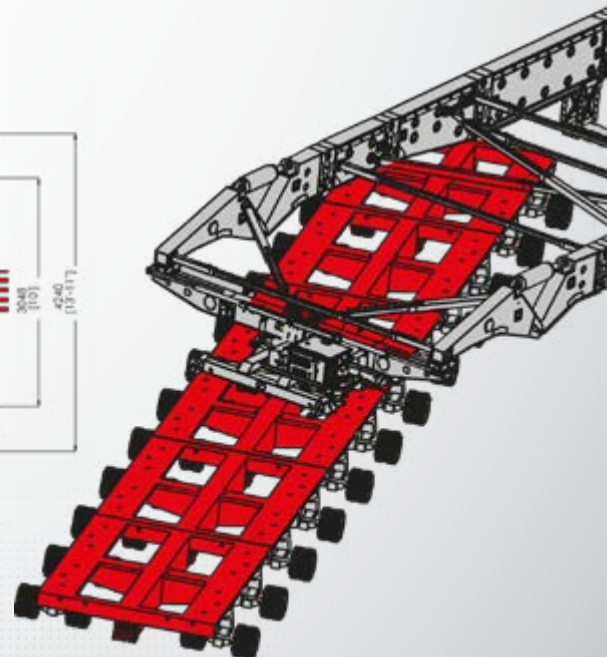
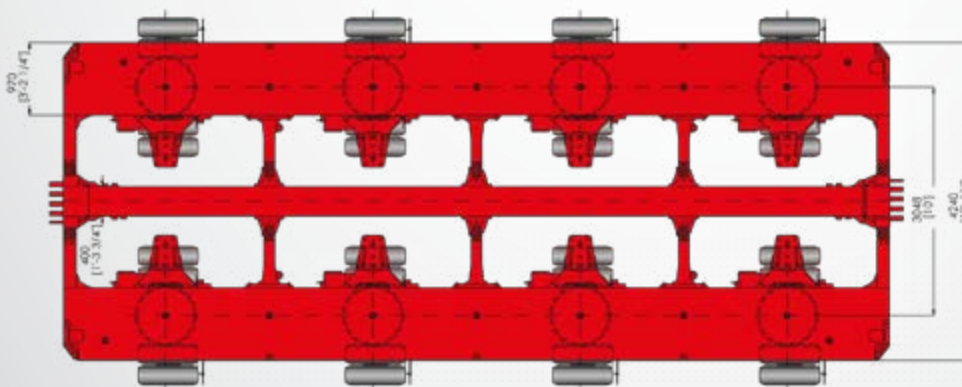
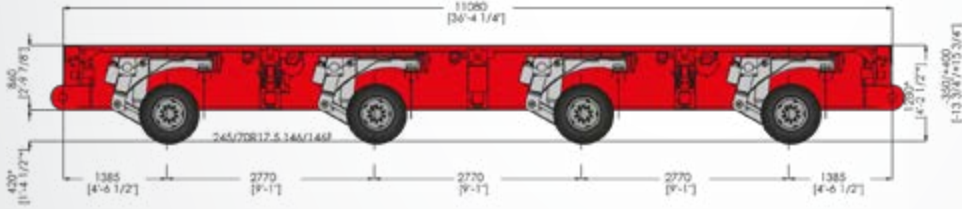
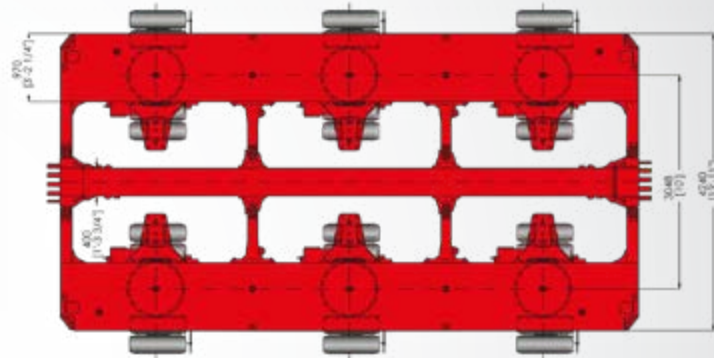
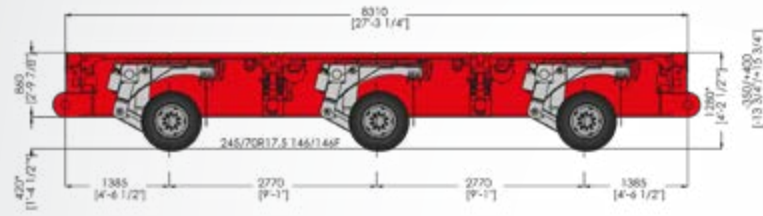
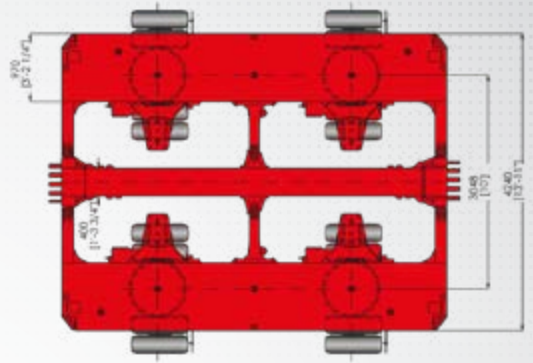
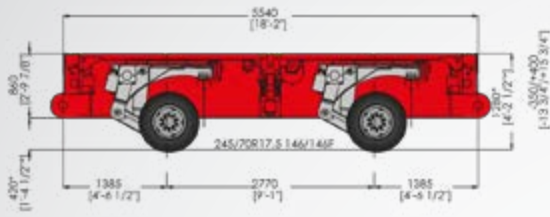

Modularity

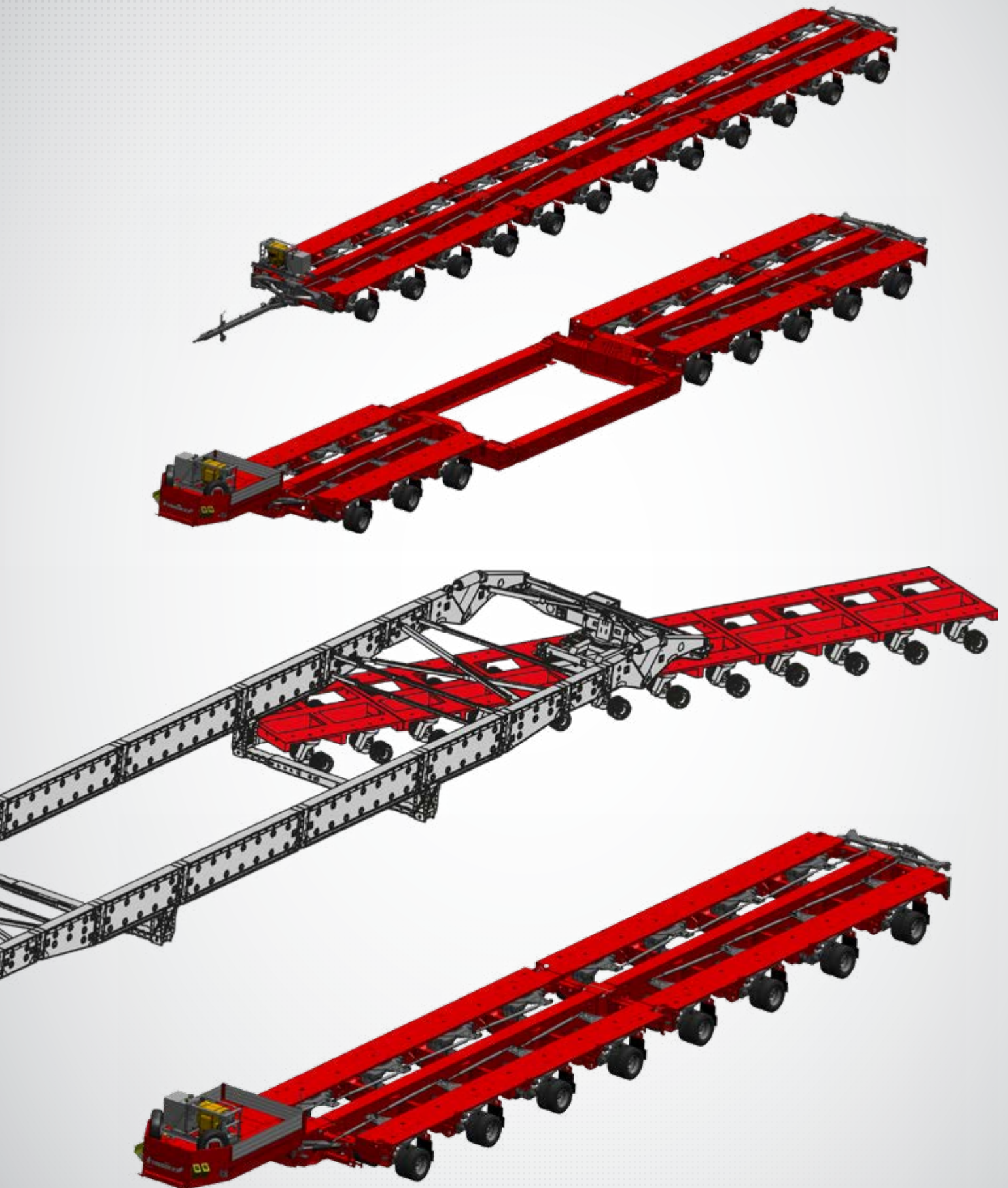



MAXPROTECT+

Weather conditions and environmental influences as well as corrosion and stone chips are the biggest enemies of a steel structure. For the long-term surface protection of semi-trailers, FAYMONVILLE relies on MAXProtect+, a fully co-ordinated and meticulously optimised surface treatment system.

MAXProtect+ is by far the best concept currently available in the industry. That is why it sets the benchmark in the field of surface protection. Our MAXProtect+ treatment offers a long-life surface protection.

All stages and processes included in MAXProtect+ – from the painting to the metallisation, including shot- and sandblasting – are carried out, developed and tested 'in-house'.

This optimum surface treatment additionally increases the quality and longevity of our products.

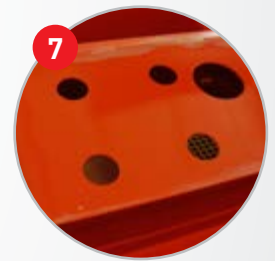

Composition of the surface refinement

- 1 Machine blasting:** Airless blast cleaning with metallic shot.
- 2 Manual blasting:** Manual cleaning and refinement of the material surface with mineral blasting agents.
- 3 Spray galvanising:** Application of a zinc/aluminium layer for corrosion and adhesion protection.
Partial metallisation especially for strongly stressed surfaces.
- 4 Joint sealing:** Prevents the spread of rust in the gap and underneath the paintwork.
- 5 Priming:** 2-component zinc epoxy with 81% zinc content and additional active corrosion protection.
- 6 Top coat:** Final coating with 2-component DTM.
- 7 Sealing:** Prevents corrosion in corners and hollow spaces.
- 8 Optional:** Seawater-resistant complete preservation



www.faymonville.us



FAYMONVILLE DISTRIBUTION AG

8, Duarrefstrooss
L-9990 WEISWAMPACH
T: +352 /26 90 04 155
sales@faymonville.com